

Hubzündungs-Innengewindebuchsen, Typ ID

Drawn arc tapped bosses, type ID



	Manuelle Zuführung oder vollautomatische Zuführung mit Sonder- rüttler Manual feed or fully automatic feed using a special feeder	Stahl 4.8 schweißgeeignet
	Bestellmenge ab 500 Stück Order quantity 500 pcs. minimum	Steel 4.8 suitable for welding

Preise auf Anfrage Prices upon request							
Länge Length	Artikel-Nr. Item No.	Artikel-Nr. Item No.	Artikel-Nr. Item No.	Artikel-Nr. Item No.	Artikel-Nr. Item No.	Artikel-Nr. Item No.	Artikel-Nr. Item No.
	M6 x Ø10 mm	M8 x Ø12 mm	--	--	--	--	--
15 mm	B90000	B90020	--	--	--	--	--
20 mm	B90002	B90022	--	--	--	--	--
25 mm	B90004	B90024	--	--	--	--	--
30 mm	B90006	B90026	--	--	--	--	--
35 mm	B90008	B90028	--	--	--	--	--
40 mm	B90010	B90030	--	--	--	--	--



Unsere Innengewindebuchsen sind in „Präzisionsdrehteilqualität“ gefertigt und sind deshalb weder preislich noch qualitativ mit gepressten/geschlagenen Buchsen vergleichbar!

Our tapped bosses are manufactured in "precision turned part quality" and are therefore not comparable with cold-pressed bosses either in price or quality.



Technische Daten | Technical Data

Innengewindebuchse ID
DIN EN ISO 13918

Tapped stud ID
DIN EN ISO 13918

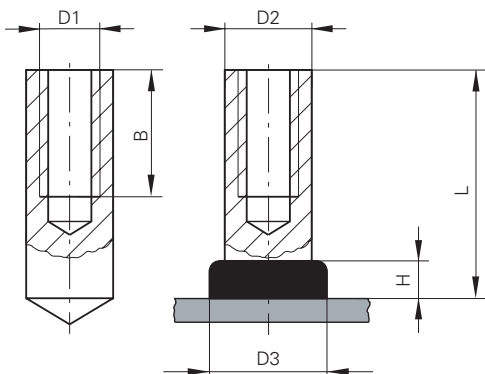

D1	M6	M8
B	L = 15 mm ≈ B 7 mm L = 20 mm ≈ B 7 mm L = 25 mm ≈ B 9 mm L = 30 mm ≈ B 9 mm L = 35 mm ≈ B 9 mm L = 40 mm ≈ B 9 mm	L = 15 mm ≈ B 9 mm L = 20 mm ≈ B 9 mm L = 25 mm ≈ B 12 mm L = 30 mm ≈ B 12 mm L = 35 mm ≈ B 12 mm L = 40 mm ≈ B 12 mm
D2	10,0	12,0
D3	13,0	16,0
H	4,0	5,0
L	siehe Abmessungen see dimensions	

Nicht angegebene Abmessungen auf Anfrage | Other dimensions on request

Alle Maße in mm | All dimensions in mm